

# SG-14/24N/24T

## Outline Drawings

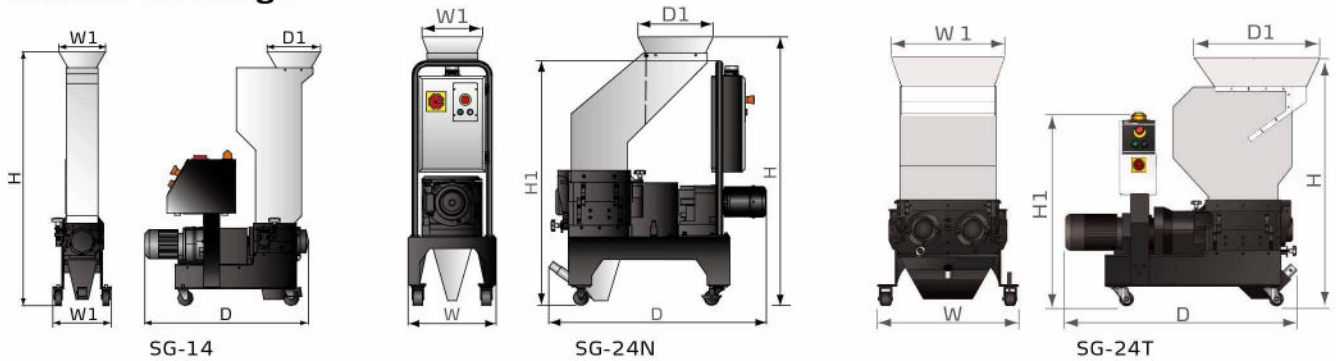

## SG-14/24N/24T Specifications

| Model                                 | SG-1411   | SG-1417   | SG-2417N  | SG-2427N  | SG-2436N   | SG-2446N   | SG-2436T     | SG-2446T  |           |      |
|---------------------------------------|-----------|-----------|-----------|-----------|------------|------------|--------------|-----------|-----------|------|
| Motor Power (kW, 50/60Hz)             | 0.37/0.45 | 0.37/0.45 | 0.75/0.86 | 0.75/0.86 | 1.5/1.75   | 2.2/2.57   | 2.2x2/2.55x2 |           |           |      |
| Rotating Speed (rpm, 50/60Hz)         | 26/32     | 26/32     | 27/33     | 27/33     | 27/33      | 27/33      | 27/33        | 27/33     |           |      |
| Material of Teeth Cutter              | SKD11     | SKD11     | SKD11     | SKD11     | SKD11      | SKD11      | SKD11        | SKD11     |           |      |
| Quantity of Staggered Cutter          | 1         | 2         | 1         | 2         | 3          | 4          | 7            | 9         |           |      |
| Quantity of Teeth Cutter              | 2         | 3         | 2         | 3         | 4          | 5          | /            | /         |           |      |
| Quantity of Large Teeth Cutter        | /         | /         | /         | /         | /          | /          | 7            | 9         |           |      |
| Quantity of Small Teeth Cutter        | /         | /         | /         | /         | /          | /          | 2            | 2         |           |      |
| Cutting Chamber                       | mm        | 140 x 110 | 140 x 175 | 240 x 175 | 240 x 270  | 240 x 365  | 240 x 460    | 505 x 365 | 505 x 460 |      |
|                                       | inch      | 5.5 x 4.3 | 5.5 x 6.9 | 9.4 x 6.9 | 9.4 x 10.6 | 9.4 x 14.4 | 9.4 x 18.1   | 19.9x14.4 | 19.9x18.1 |      |
| Max. Output Capacity (kg/hr, 50/60Hz) | 2         | 3         | 3.5       | 6/6.5     | 8.5/9      | 11/11.6    | 20           | 25        |           |      |
| Noise Level dB(A)                     | 60-68     | 60-68     | 80-85     | 80-85     | 80-85      | 80-85      | 80-85        | 80-85     |           |      |
| Dimension                             | H         | mm        | 1080      | 1080      | 1370       | 1370       | 1400         | 1410      | 1360      | 1360 |
|                                       |           | inch      | 42.5      | 42.5      | 53.9       | 53.9       | 55.1         | 55.5      | 53.5      | 53.5 |
|                                       | H1        | mm        | /         | /         | 1248       | 1248       | 1248         | 1248      | 1060      | 1060 |
|                                       |           | inch      | /         | /         | 49.1       | 49.1       | 49.1         | 49.1      | 41.7      | 41.7 |
|                                       | W         | mm        | 290       | 290       | 425        | 425        | 425          | 425       | 773       | 773  |
|                                       |           | inch      | 11.4      | 11.4      | 16.7       | 16.7       | 16.7         | 16.7      | 30.4      | 30.4 |
|                                       | W1        | mm        | 235       | 235       | 308        | 308        | 308          | 308       | 620       | 620  |
|                                       |           | inch      | 9.3       | 9.3       | 12.1       | 12.1       | 12.1         | 12.1      | 24.4      | 24.4 |
|                                       | D         | mm        | 740       | 785       | 977        | 1112       | 1253         | 1410      | 1269      | 1365 |
|                                       |           | inch      | 29.1      | 30.9      | 38.5       | 43.8       | 49.3         | 55.5      | 50        | 53.7 |
|                                       | D1        | mm        | 210       | 266       | 289        | 385        | 475          | 546       | 688       | 785  |
|                                       |           | inch      | 8.3       | 10.5      | 11.4       | 15.2       | 18.7         | 21.5      | 27        | 30.9 |
| Weight                                | kg        | 83        | 92        | 215       | 240        | 257        | 330          | 530       | 560       |      |
|                                       | lb        | 183       | 203       | 474       | 529        | 567        | 728          | 1168      | 1235      |      |

- Notes: 1) Max. Capacity of the machine is subject to the size and composition of the material.  
 2) Noise level will varies with different materials and motor types.  
 3) SKD11 is JIS steel grade.  
 4) teeth cutter with width of 3mm is standard, and 4mm is optional (SG-14).  
 Trapezoidal teeth cutter is standard; narrow and dilated one are optional (SG-14N/24T).  
 5) To avoid plastic from sticking to the blades, all materials should be crushed at normal temperature.  
 6) Power supply: 3Φ, 230/400/460/575 VAC, 50/60Hz.

We reserve the right to change specifications without prior notice.